

Impiego	Use	Verwendung	Uso	Utilisation
---------	-----	------------	-----	-------------

La testata interfilare IT è un accessorio applicabile alla trincia ed è utile per la pulizia attorno al fusto delle piante e dell'interfila, senza provocare danni alla corteccia.

The IT inter-row head accessory fits on the mulcher and cleans around the stems of crop plants and in alleyways without damaging the crop plants themselves.

Die IT Mähscheibe passt auf den Mulcher und ist so konstruiert, dass sie das Gras um die Bäume herum mäht, ohne die Ernte zu beschädigen.

El cabezal interlíneas IT es un accesorio que se monta en la trituradora y que sirve para limpiar alrededor de las plantas y las interlíneas sin dañar la corteza.

La tête inter-rangs IT est un accessoire applicable au broyeur, utile pour le nettoyage autour du tronc des plants et dans les espaces inter-rangs, sans endommager l'écorce.



Sistema BREVETTATO di fissaggio del filo
Wire fixing PATENTED system
PATENTIERTES System zur Drahtbefestigung
Sistema PATENTADO de fijación de hilo
Système BREVETÉ de fixation du fil



Versione con lame
Version with blades - Version mit Messern
Versión con cuchillas - Version avec lames

Versione con filo
Wire version - Version mit Faden
Versión con hilo - Version avec fil

Ø 50								
mod.	cm	kg	cod.	nr		cod.	nr	
IT / TFZ	50	120	1002546	2		1003207	4	
IT / TMU	50	120	1002563	2		1003799	4	
IT / LFG	50	120	1002594	2		1003208	4	
IT / TFB	50	120	1002625	2		1003209	4	
IT / TFA / TFO	50	120	1002821	2		1003210	4	
IT / TRE-PRO	50	120	1002951	2		1003211	4	

Ø 70								
mod.	cm	kg	cod.	nr		cod.	nr	
IT / TFZ	70	135	1002909	2		1003212	4	
IT / TMU	70	135	1002911	2		1003213	4	
IT / LFG	70	135	1002913	2		1003214	4	
IT / TFB	70	135	1002914	2		1003215	4	
IT / TFA / TFO	70	135	1002915	2		1003216	4	
IT / TRE-PRO	70	135	1002952	2		1003101	4	

Di serie	Standard equipment	Serienmässig	Estándar	De série
<ul style="list-style-type: none"> Distributore di esclusione della testata interfilare Distributore accensione del gruppo lame Serbatoio di olio da 40 litri Kit attacco pompa Protezioni antinfortunistiche conformi alla normativa CE 	<ul style="list-style-type: none"> Inter-row head retraction distributor Cutter drive distributor 40 liters hydraulic fluid tank Pump drive kit Protective equipment as per EC safety rules 	<ul style="list-style-type: none"> Ausschlussverteilergetriebe des interfilaren Kopfs Verteilergetriebe und Einschalten Schnittblattgruppe 40 l - Ölbehälter Pumpenanschluss Unfallschutz nach EU-Vorschriften 	<ul style="list-style-type: none"> Distribuidor de desactivación del cabezal interlíneas Distribuidor y encendido del grupo de cuchillas Depósito de aceite de 40 litros Kit de conexión de bomba Protecciones de seguridad de acuerdo con la norma CE 	<ul style="list-style-type: none"> Distributeur d'exclusion de la tête inter-rangs Distributeur et allumage du groupe des lames Réservoir d'huile de 40 litres Kit de raccord pompe Protections contre les accidents aux normes CE

IT	INTER-ROW DISC FOR MULCHER
IT	HYDRAULISCHE SCHWENKSCHIBE FÜR MULCHER
IT	CABEZAL INTERFILAR CON PALPADOR HIDRÁULICO
IT	TÊTE INTER-RANGS AVEC PALPEUR HYDRAULIQUE



zanon.it

Il disco interfilare è montato su un sistema di parallele che lo rende flottante, consentendogli di adattarsi ad eventuali irregolarità del terreno. È, inoltre, possibile regolare l'inclinazione del disco interfilare, così da poter lavorare anche su dirupi o scoli.

The inter-row cutter disk is mounted on a parallel guide system that leaves it float and follow the surface of uneven ground. The angle of the inter-row cutter disk can be adjusted to cut the edges of embankments and drainage channels.

Die Mähscheibe ist auf einem System von Parallelen montiert, das sie schwimmend macht, so dass sie sich an alle Unebenheiten des Bodens anpassen kann. Es ist auch möglich, die Neigung der Scheibe einzustellen.

El disco interlíneas está montado en un sistema de paralelas y es flotante para permitirle seguir las irregularidades del terreno. También es posible regular la inclinación del disco interlíneas, para poder trabajar en canales y pendientes.

Le disque inter-rangs est monté sur un système de guidages parallèles qui le rend flottant, en lui permettant de s'adapter aux éventuelles irrégularités du sol. Il est possible également de régler l'inclinaison du disque inter-rangs de manière à pouvoir travailler aussi sur les pentes raides ou les fossés.

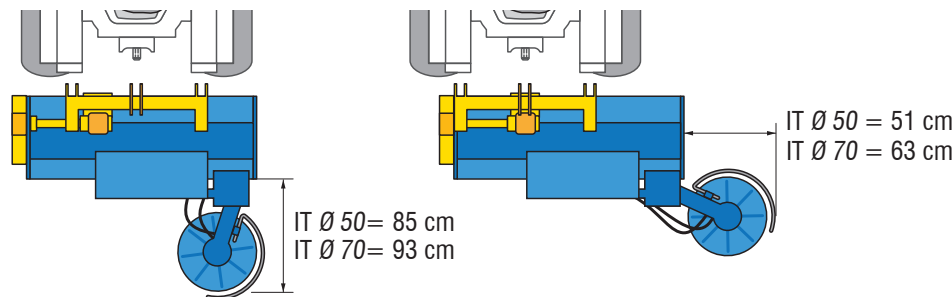
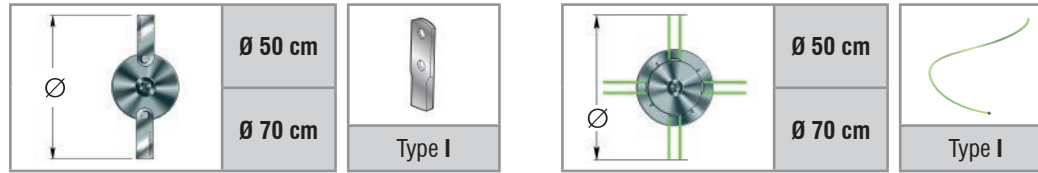

MOVIMENTO 1 / MOVEMENT 1

Inclinazione testata
Inter-row disc inclination
Zwischenreihenscheibe neigung
Inclinación de disco entre hileras
Disque inter-rangée



MOVIMENTO 2 / MOVEMENT 2

Regolazione meccanica altezza asse
Arm's height mechanical adjustment
Mechanische Einstellung Arbeitsposition
Regulación de altura
Réglage hauteur axe

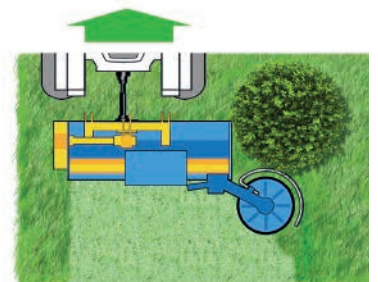
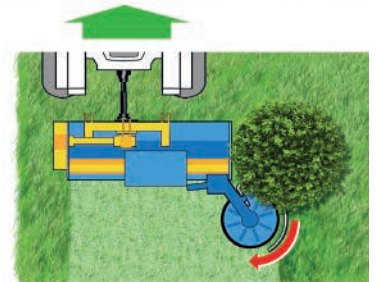
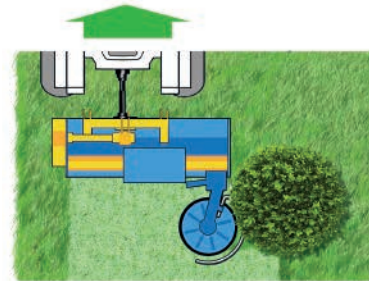
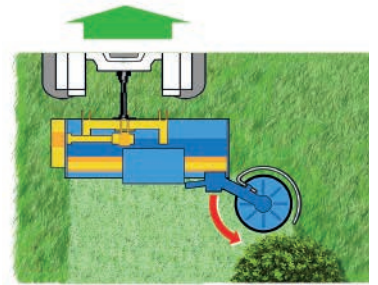

cod.	A richiesta	On request	Auf Anfrage	Opcionales	Sur demande
5444295	Kit richiamo testata meccanico direttamente dal trattore	Mechanical head recall kit directly from the tractor	Mechanischer Kopf-Rücklaufsatz direkt vom Traktor	Kit de accionamiento del cabezal directamente del tractor	Kit arret tete mecanique directement de le tracteur
2051251	Kit trasformazione da lame a filo per IT Ø50/Ø70	Conversion kit from blades to wire for IT Ø50 / Ø70	Umrüstsatz von Klingen auf Draht für IT Ø50 / Ø70	Kit de conversión de cuchillas a hilo para IT Ø50 / Ø70	Kit de conversion de lames à fil pour IT Ø50 / Ø70

cod.	Ricambi	Spare parts	Ersatzteile	Recambios	Pièces de rechange
5110025	Semigiunto	Half coupling	Kupplungshälfte	Mitad de acoplamiento	Demi-accouplement
5421016	Pompa doppia	Double pump	Doppelpumpe	Bomba doble	Pompe double
5421015	Motore testata (Ø 70)	Inter-row motor (Ø 70)	Zwischenreihen-Vorsatzgerät Mot. (Ø 70)	Motor de cabezal (Ø 70)	Moteur tete (Ø 70)
5421019	Motore testata (Ø 50)	Inter-row motor (Ø 50)	Zwischenreihen-Vorsatzgerät Mot. (Ø 50)	Motor de cabezal (Ø 50)	Moteur tete (Ø 50)
5314009	Filtro	Filter	Filter	Filtro	Filtre
5350117	Lama	Blade	Messer	Cuchilla	Couteau
5335027	Tastatore	Hyd. Finger	Schwenscheibe	Palpador	Palpeur

Impiego	Use	Verwendung	Uso	Utilisation
---------	-----	------------	-----	-------------

Il disco interfilare a molla IT-M viene applicato alle nostre trincia e permette il taglio dell'erba nell'interceppo senza l'uso di tastatori. Il disco interfilare, grazie ad una molla di richiamo, quando entra a contatto con il fusto della pianta rientra senza causare danni alla stessa.

The IT-M spring-loaded inter-row disc is fitted to our mulchers and allows the grass to be cut in the inter-row without the use of sensors. The inter-row disc, thanks to a return spring, returns when it comes into contact with the plant stem without causing damage to the plant.

Die federbelastete IT-M Zwischenreihen-Scheibe ist an unseren Mulchern angebracht und ermöglicht das Schneiden des Grases in der Zwischenreihe ohne den Einsatz von Sensoren. Die Zwischenreihenscheibe kehrt dank einer Rückholfeder zurück, wenn sie mit dem Pflanzestamm in Berührung kommt, ohne die Pflanze zu beschädigen.

El disco interfilare IT-M accionado mediante muelle, se puede aplicar a la gama de desbrozadoras/trituradoras no reversibles disponibles, permitiendo el corte de la broza entre los centros de las plantas. El disco interfilare, gracias a su muelle regulable en tensión, al entrar en contacto con el tronco de la planta, se retira del centro de la misma, cortando la broza en torno a ella y no efectúa daños en ella.

Le disque interligne IT-M avec retour à ressort monté sur nos broyeurs permet de couper l'herbe entre les interceps sans l'utilisation de le palpeur hydraulique. Le disque interligne, grace à sa ressort speciale, pendant le contact avec la plante ne cause aucun dégât à la même.

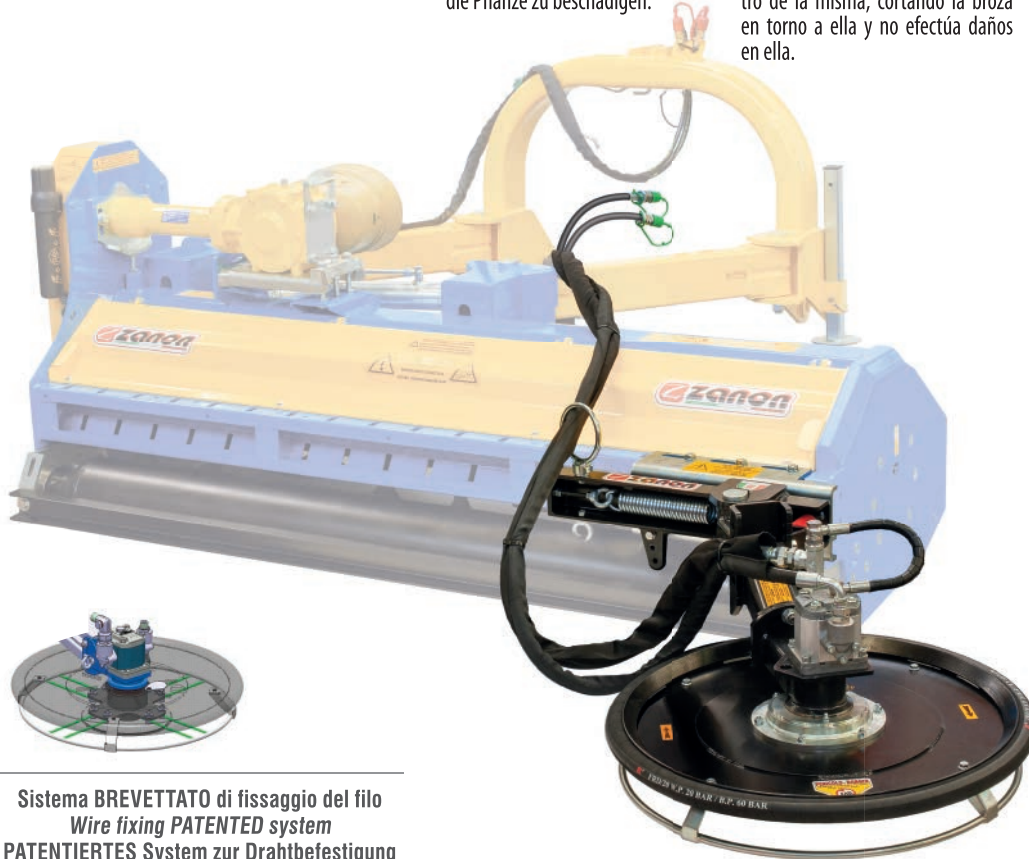

Sistema BREVETTATO di fissaggio del filo
Wire fixing PATENTED system
PATENTIERTES System zur Drahtbefestigung
Sistema PATENTADO de fijación de hilo
Système BREVETÉ de fixation du fil

Versione con lame
Version with blades - Version mit Messern
Versión con cuchillas - Version avec lames

Versione con filo
Wire version - Version mit Faden
Versión con hilo - Version avec fil

Ø 60								
mod.	cm	kg	l/min	cod.	nr	cod.	nr	
IT-M / TFZ	60	90	35	1003219	2	1003811	4	
IT-M / TMU	60	90	35	1003220	2	1003800	4	
IT-M / LFG	60	90	35	1003221	2	1003801	4	
IT-M / TFB	60	90	35	1003222	2	1003802	4	
IT-M / TFA / TFO	60	90	35	1003223	2	1003803	4	
IT-M / TRE-PRO	60	90	35	1003224	2	1003804	4	

Ø 80								
mod.	cm	kg	l/min	cod.	nr	cod.	nr	
IT-M / TFZ	80	110	35	1003225	2	1003805	4	
IT-M / TMU	80	110	35	1003226	2	1003806	4	
IT-M / LFG	80	110	35	1003227	2	1003807	4	
IT-M / TFB	80	110	35	1003228	2	1003808	4	
IT-M / TFA / TFO	80	110	35	1003229	2	1003809	4	
IT-M / TRE-PRO	80	110	35	1003230	2	1003810	4	

IT-M	INTER-ROW DISC FOR MULCHER WITH RETURN SPRING
IT-M	SCHWENKSCHLEIBE FÜR MULCHER FEDERBELASTET
IT-M	CABEZAL INTERFILAR CON RETORNO A MUELLE
IT-M	TÊTE INTER-RANGS AVEC RETOUR AU RESSORT



zanon.it

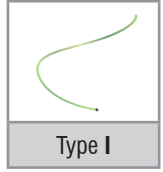
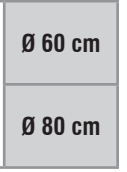
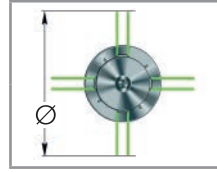
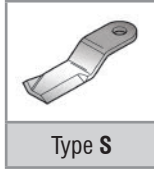
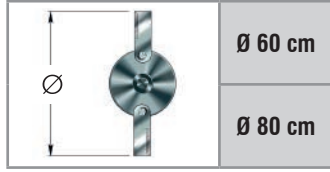
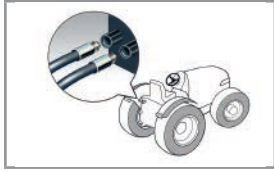

Il disco interfilare è montato su un sistema di parallele che lo rende flottante, consentendogli di adattarsi ad eventuali irregolarità del terreno.

È inoltre possibile regolare l'inclinazione del disco interfilare, così da poter lavorare anche su dirupi o scoli.

L'attrezzo richiede una coppia di prese idrauliche al trattore (il trattore deve essere dotato di scarico libero) e minimo 35 lt/min di olio dal trattore.

The inter-row cutter disk is mounted on a parallel guide system that leaves it float and follow the surface of uneven ground. The angle of the inter-row cutter disk can be adjusted to cut the edges of embankments and drainage channels.

The implement requires a pair of hydraulic connections to the tractor (the tractor must be equipped with free drainage) and a minimum of 35 l/min of oil from the tractor.

Die Mähscheibe ist auf einem System von Parallelen montiert, das sie schwimmend macht, so dass sie sich an alle Unebenheiten des Bodens anpassen kann. Es ist auch möglich, die Neigung der Scheibe einzustellen.

Das Gerät benötigt ein Paar hydraulische Anschlüsse zum Traktor (der Traktor muss mit freiem Abfluss ausgestattet sein) und eine Mindestmenge von 35 l/min vom Traktor.

El disco interlíneas está montado en un sistema de paralelas y es flotante para permitirle seguir las irregularidades del terreno. También es posible regular la inclinación del disco interlíneas, para poder trabajar en canales y pendientes. El interfilar va acoplado al hidráulico del tractor, por lo tanto se requieren un distribuidor doble y con la descarga directa al tanque, la capacidad mínima de aceite necesaria para el accionamiento del interfilar es de 35 litros.

Le disque inter-rangs est monté sur un système de guidages parallèles qui le rend flottant, en lui permettant de s'adapter aux éventuelles irrégularités du sol. Il est possible également de régler l'inclinaison du disque inter-rangs de manière à pouvoir travailler aussi sur les pentes raides ou les fossés. L'outil exige deux prises hydrauliques côté tracteur (le tracteur doit avoir le décharge libre) et au moins 35 lt/min d'huile de le circuit du tracteur.

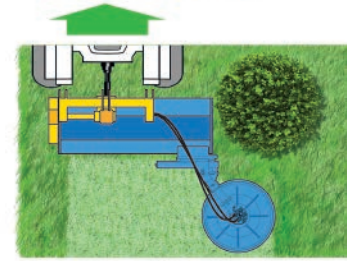
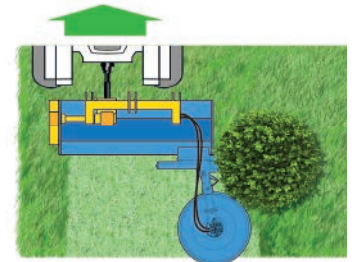
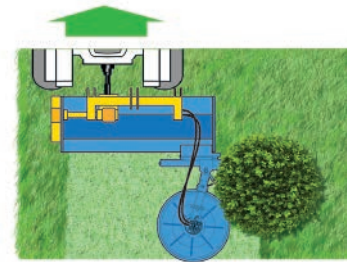
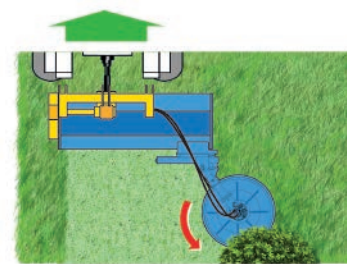
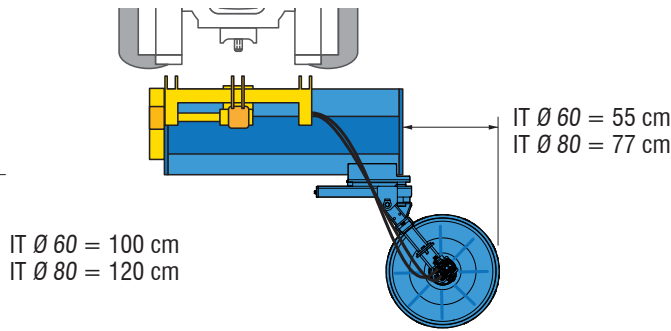
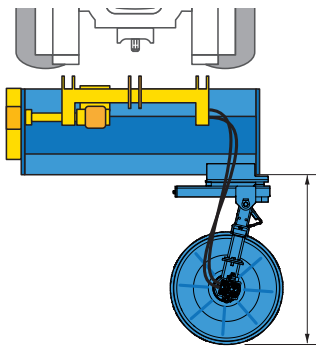

MOVIMENTO 1 / MOVEMENT 1

Inclinazione testata
Inter-row disc inclination
Zwischenreihenscheibe neigung
Inclinación de disco entre hileras
Disque inter-rangée



MOVIMENTO 2 / MOVEMENT 2

Regolazione meccanica altezza asse
Arm's height mechanical adjustment
Mechanische Einstellung Arbeitsposition
Regulación de altura
Réglage hauteur axe



cod.	A richiesta	On request	Auf Anfrage	Opcionales	Sur demande
2051250	Kit trasformazione da lame a filo per IT-M Ø60/Ø80	Conversion kit from blades to wire for IT-M Ø60/Ø80	Umrüstsatz von Klingen auf Draht für IT-M Ø60/Ø80	Kit de conversión de cuchillas a hilo para IT-M Ø60/Ø80	Kit de conversion de lames à fil pour IT-M Ø60/Ø80
cod.	Ricambi	Spare parts	Ersatzteile	Recambios	Pièces de rechange
5421033	Motore testata	Inter-row motor	Zwischenreihen-Vorsatzgerät Motor	Motor de cabezal	Moteur tête
5350165	Lama	Blade	Messer	Cuchilla	Couteau
5335070	Molla rientro testata	Return spring	Rückholfeder	Muelle de retorno	Ressort de rappel

Impiego	Use	Verwendung	Uso	Utilisation
---------	-----	------------	-----	-------------

La testata interfilare IT-PRO è un accessorio applicabile alla trincia ed è utile per la pulizia attorno al fusto delle piante e dell'interfila, senza provocare danni alla corteccia.

The IT-PRO inter-row head accessory fits on the mulcher and cleans around the stems of crop plants and in alleyways without damaging the crop plants themselves.

Die IT-PRO Mähsscheibe passt auf den Mulcher und ist so konstruiert, dass sie das Gras um die Bäume herum mäht, ohne die Ernte zu beschädigen.

El cabezal interlíneas IT-PRO es un accesorio que se monta en la trituradora y que sirve para limpiar alrededor de las plantas y las interlíneas sin dañar la corteza.

La tête inter-rangs IT-PRO est un accessoire applicable au broyeur, utile pour le nettoyage autour du tronc des plants et dans les espaces inter-rangs, sans endommager l'écorce.

Di serie

- Serbatoio olio indipendente 40 lt
- Doppio sistema filtrante
- Kit attacco pompa
- Scambiatore di calore
- Joystick multifunzione
- Regolazione inclinazione, apertura/chiusura testata, on/off rotore, tutto tramite joystick
- Protezioni antinfortunistiche conformi alla normativa CE

Standard equipment

- Independent oil tank 40 lt
- Double filtering system
- Pump connection kit
- Heat exchanger
- Multifunction Joystick
- Tilt adjustment, opening/closing head, on/off rotor, all with joystick
- Protective equipment as per EC safety rules

Estándar

- Depósito de aceite independiente de 40 litros
- Sistema doble filtrante
- Kit acople bomba
- Intercambiador de calor
- Joystick multifunción
- Ajuste de inclinación, apertura/cierre de la cabeza, encendido/apagado rotor, todo con joystick
- Protecciones de seguridad de acuerdo con la norma CE

Serienmässig

- Unabhängiger Öltank 40 lt
- Doppeltes Filtersystem
- Pumpenanschluss-Satz
- Wärmetauscher
- Multifunktions-Joystick
- Neigungsverstellung, Öffnungs-/Schließkopf, Ein/Aus-Rotor, alle mit Joystick
- Unfallschutz nach EU-Vorschriften

De série

- Réservoir d'huile indépendant de 40 l
- Double système de filtration
- Kit connexion pompe
- Echangeur de chaleur
- Joystick multifonction
- Réglage de l'inclinaison, ouverture/fermeture de la tête, marche/arrêt rotor, tout avec joystick
- Protections contre les accidents aux normes CE



JOYSTICK MULTIFUNZIONE

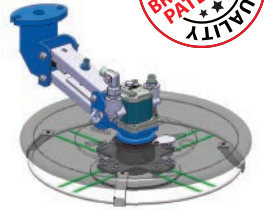

Sistema BREVETTATO di fissaggio del filo
Wire fixing PATENTED system
PATENTIERTES System zur Drahtbefestigung
Sistema PATENTADO de fijación de hilo
Système BREVETÉ de fixation du fil

Versione con lame
 Version with blades - Version mit Messern
 Versión con cuchillas - Version avec lames

Versione con filo
 Wire version - Version mit Faden
 Versión con hilo - Version avec fil

Ø 50		Ø 70				
mod.	cm	kg	cod.	nr	cod.	nr
IT-PRO / TFZ	50	130	1003183	2	1003195	4
IT-PRO / TMU	50	130	1003184	2	1003196	4
IT-PRO / LFG	50	130	1003185	2	1003197	4
IT-PRO / TFB	50	130	1003186	2	1003198	4
IT-PRO / TFA / TFO	50	130	1003187	2	1003199	4
IT-PRO / TRE-PRO	50	130	1003188	2	1003200	4
IT-PRO / TFZ	70	145	1003189	2	1003201	4
IT-PRO / TMU	70	145	1003190	2	1003202	4
IT-PRO / LFG	70	145	1003191	2	1003203	4
IT-PRO / TFB	70	145	1003192	2	1003204	4
IT-PRO / TFA / TFO	70	145	1003193	2	1003205	4
IT-PRO / TRE-PRO	70	145	1003194	2	1003206	4

IT-PRO	INTER-ROW DISC FOR MULCHER WITH HYDRAULIC PROBE with JOYSTICK
IT-PRO	HYDRAULISCHE SCHWENKSCHIBE FÜR MULCHER mit JOYSTICK
IT-PRO	CABEZAL INTERFILAR CON PALPADOR HIDRÁULICO con JOYSTICK
IT-PRO	TÊTE INTER-RANGS AVEC PALPEUR HYDRAULIQUE avec JOYSTICK



ORIGINAL MADE IN ITALY | zanon.it

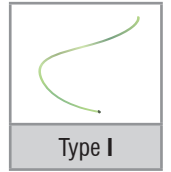
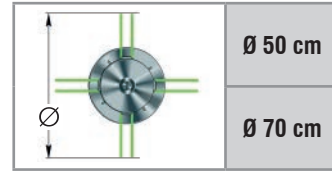
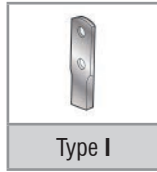
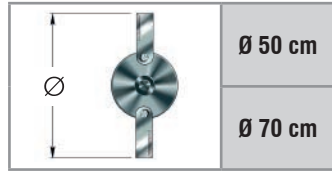
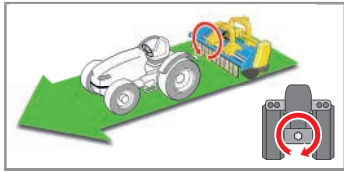

Il disco interfilare è montato su un sistema di parallele che lo rende flottante, consentendogli di adattarsi ad eventuali irregolarità del terreno. È, inoltre, possibile regolare l'inclinazione del disco interfilare, così da poter lavorare anche su dirupi o scoli.

The inter-row cutter disk is mounted on a parallel guide system that leaves it float and follow the surface of uneven ground. The angle of the inter-row cutter disk can be adjusted to cut the edges of embankments and drainage channels.

Die Mähscheibe ist auf einem System von Parallelen montiert, das sie schwimmend macht, so dass sie sich an alle Unebenheiten des Bodens anpassen kann. Es ist auch möglich, die Neigung der Scheibe einzustellen.

El disco interlíneas está montado en un sistema de paralelas y es flotante para permitirle seguir las irregularidades del terreno. También es posible regular la inclinación del disco interlíneas, para poder trabajar en canales y pendientes.

Le disque inter-rangs est monté sur un système de guidages parallèles qui le rend flottant, en lui permettant de s'adapter aux éventuelles irrégularités du sol. Il est possible également de régler l'inclinaison du disque inter-rangs de manière à pouvoir travailler aussi sur les pentes raides ou les fossés.

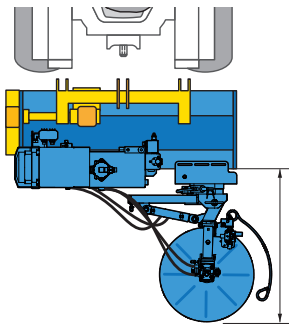

IT Ø 50 = 85 cm
IT Ø 70 = 93 cm

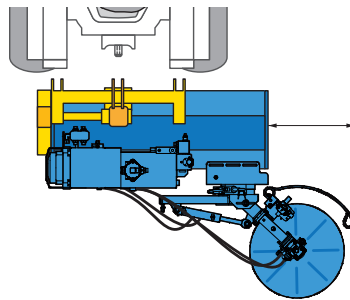

IT Ø 50 = 51 cm
IT Ø 70 = 63 cm

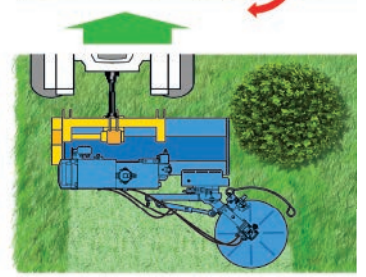
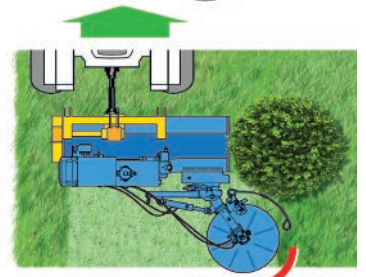
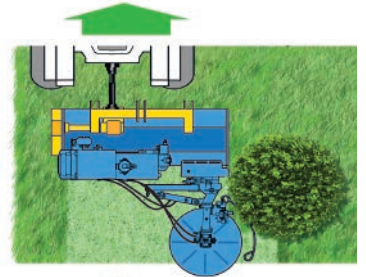
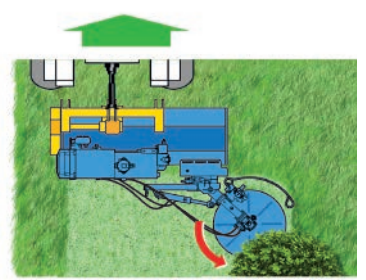

MOVIMENTO 1 / MOVEMENT 1

Inclinazione testata (con joystick multifunzione)

Inter-row disc inclination (with multifunction joystick)

Zwischenreihenscheibe neigung (mit Multifunktions-Joystick)

Inclinación de disco entre hileras (con joystick multifunción)

Disque inter-rangée (avec joystick multifonction)



Joystick MULTIFUNZIONE
+15°
-15°

MOVIMENTO 2 / MOVEMENT 2

Regolazione meccanica altezza asse

Arm's height mechanical adjustment

Mechanische Einstellung Arbeitsposition

Regulación de altura

Réglage hauteur axe



cod.	A richiesta	On request	Auf Anfrage	Opcionales	Sur demande
2051251	Kit trasformazione da lame a filo per IT Ø50/Ø70	Conversion kit from blades to wire for IT Ø50 / Ø70	Umrüstsatz von Klingen auf Draht für IT Ø50 / Ø70	Kit de conversión de cuchillas a hilo para IT Ø50 / Ø70	Kit de conversion de lames à fil pour IT Ø50 / Ø70
cod.	Ricambi	Spare parts	Ersatzteile	Recambios	Pièces de rechange
5110025	Semigiunto	Half coupling	Kupplungshälfte	Mitad de acoplamiento	Demi-accouplement
5421046	Pompa singola	Single pump	Einzelpumpe	Bomba simple	Pompe simple
5421019	Motore testata	Inter-row motor	Zwischenreihen-Vorsatzgerät	Motor de cabezal	Moteur tete
5314020	Filtro	Filter	Filter	Filtro	Filtre
5350117	Lama	Blade	Messer	Cuchilla	Couteau
5450065	Bobina filo 155 mt Ø 6 mm	Wire 155 mt Ø 6 mm	Garnrolle 155 mt Ø 6 mm	Hilo 155 mt Ø 6 mm	Bobine de fil 155 mt Ø 6 mm
5335027	Tastatore	Hyd. Finger	Schwenscheibe	Palpador	Palpeur

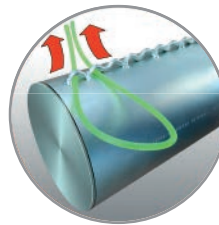
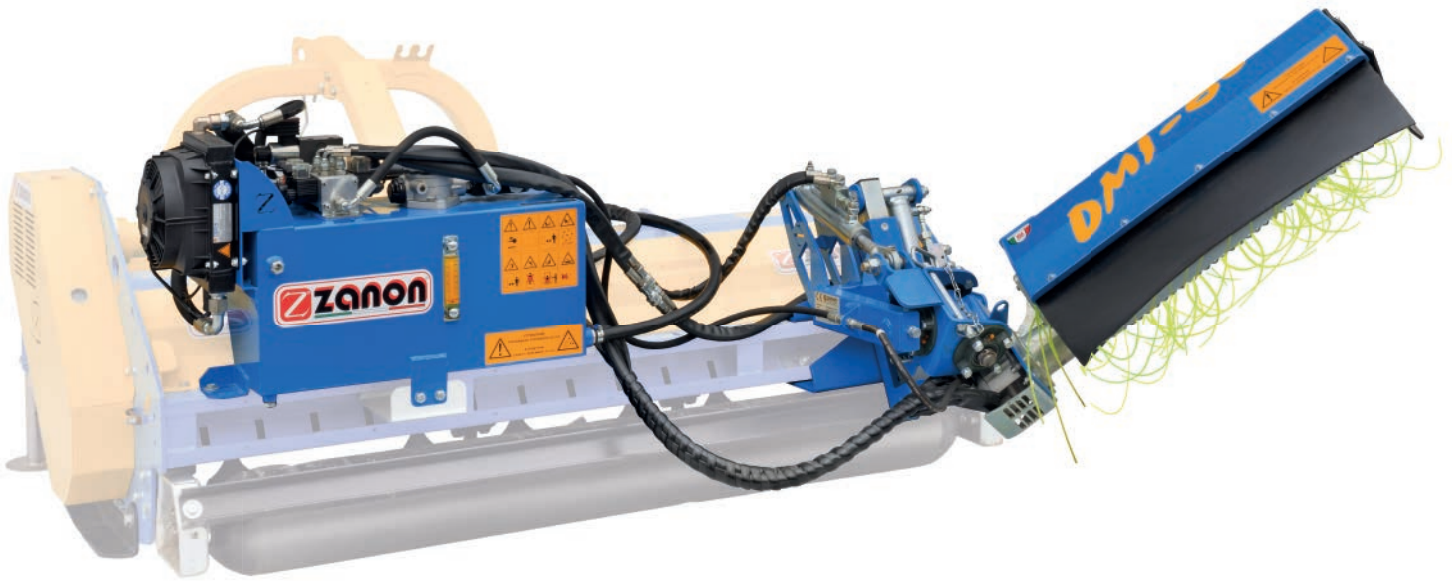

Sistema rapido per il cambio dei fili
 Quick and tool-free wire replacement system
 Schnelles und werkzeugloses Drahtwechselsystem
 Sistema cambio de hilo rápido
 Système rapide de remplacement du fil

MOD		
mod.	cod.	kg
DMI / TFZ	1002882	280
DMI / TMU	1002884	280
DMI / LFG	1002886	280
DMI / TFB	1002887	280
DMI / TFA	1002888	280
DMI / TRE	1003005	280

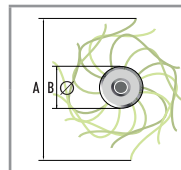

Ø A
450 mm

Ø B
130 mm

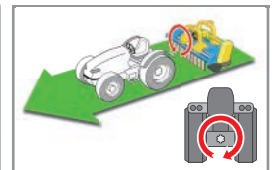
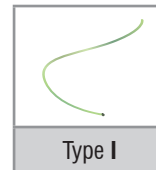

Di serie	Standard equipment	Serienmässig	Estándar	De série
<ul style="list-style-type: none"> Seratoio da 40 litri indipendente Doppio sistema filtrante Kit attacco pompa Raccorderia oleodinamica con attacchi a sgancio rapido per una veloce rimozione della macchina Kit scambiatore di calore Posizioni di lavoro gestite direttamente dalla trattrice tramite Joystick multifunzione removibile Regolazione giri motore Blocco distribuzione gestito elettronicamente Accensione-spegnimento 1 set di fili pre-installato Sistema rapido per il cambio dei fili Protezioni antinfortunistiche conformi alla normativa CE 	<ul style="list-style-type: none"> Independent 40 liters tank Double filtering system Pump connection kit Hydraulic fittings with quick release connections for a quick removal of the machine Heat exchanger kit Working positions managed directly by the tractor using a removable multifunction joystick Engine revolutions adjustment Electronically managed distribution block On-off switching 1 set of pre-installed wires Quick and tool-free wire replacement system Protective equipment as per EC safety rules 	<ul style="list-style-type: none"> Unabhängiger 40Lt Tank Doppeltes Filtersystem Pumpenverbindingssatz Hydraulische Armaturen mit Schnellkupplungen für eine schnelle Demontage der Maschine Wärmetauscher-Kit Direkte Steuerung der Arbeitspositionen durch den Traktor mit einem abnehmbaren Multifunktions-Joystick Einstellung der Motordrehzahl Elektronisch gesteuerter Verteilerblock Ein-Aus-Schaltung 1 Satz vorinstallierter Drähte Schnelles und werkzeugloses Drahtwechselsystem Unfallschutz nach EU-Vorschriften 	<ul style="list-style-type: none"> Tanque de 40 litros independiente Doble sistema de filtrado Kit de conexión de bomba Accesorios hidráulicos con conexiones de liberación rápida para una rápida extracción de la máquina Kit de intercambiador de calor Posiciones de trabajo gestionadas directamente por el tractor mediante un joystick Ajuste de revoluciones del motor Bloque de distribución gestionado electrónicamente Encendido-apagado 1 juego de cables preinstalados Sistema cambio de hilo rápido Protecciones de seguridad de acuerdo con la norma CE 	<ul style="list-style-type: none"> Réservoir indépendant 40 litres Système de double filtration Kit de connexion de pompe Raccords hydrauliques avec raccords rapides pour un retrait rapide de la machine Kit échangeur de chaleur Positions de travail gérées directement par le tracteur à l'aide d'un joystick multifonction amovible Réglage de la rotation du moteur Bloc de distribution géré électroniquement Commutation marche-arrêt 1 jeu de fils pré-installés Système rapide de remplacement du fil Protections contre les accidents aux normes CE

cod.	Ricambi	Spare parts	Ersatzteile	Recambios	Pièces de rechange
5450043	Bobina filo 630 mt Ø 4 mm	Wire 630 mt Ø 4 mm	Garnrolle 630 mt Ø 4 mm	Hilo 630 mt Ø 4 mm	Bobine de fil 630 mt Ø 4 mm

DMI	INTER-ROW WEEDER FOR FLAIL MOWER
DMI	MECHANISCHE UNKRAUTMÄHBÜRSTE FÜR MULCHER
DMI	DESBROZADORA INTERFILA MECÁNICA
DMI	MACHINE À ÉBOURGEONNER AVEC PALPEUR MÉCANIQUE



ORIGINAL MADE IN ITALY | zanon.it

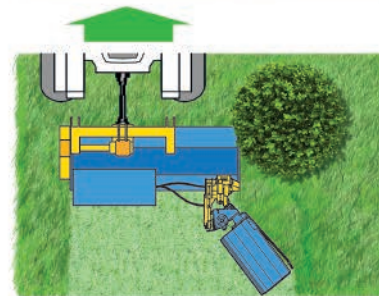
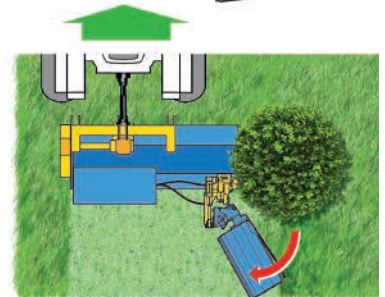
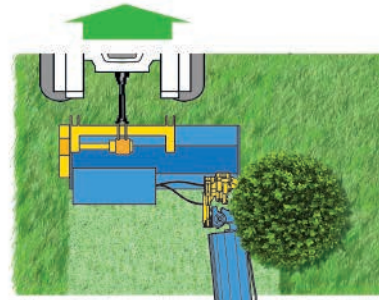
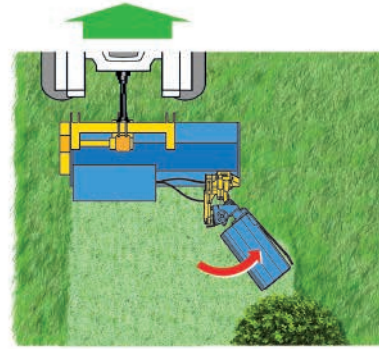
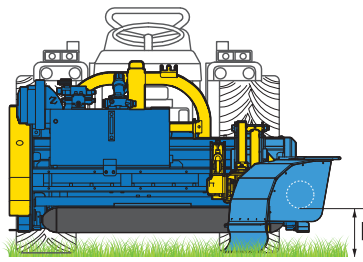
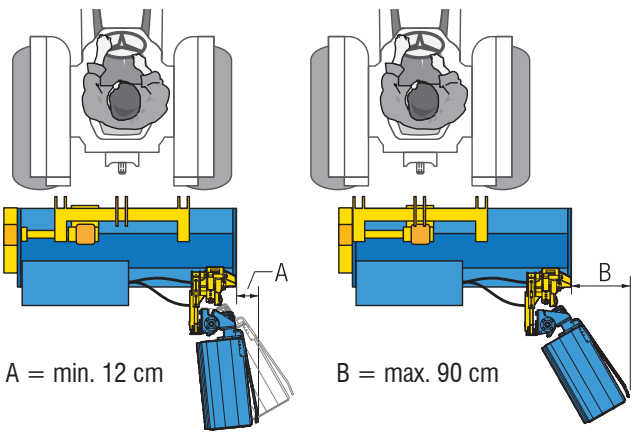

MOVIMENTO 1 / MOVEMENT 1

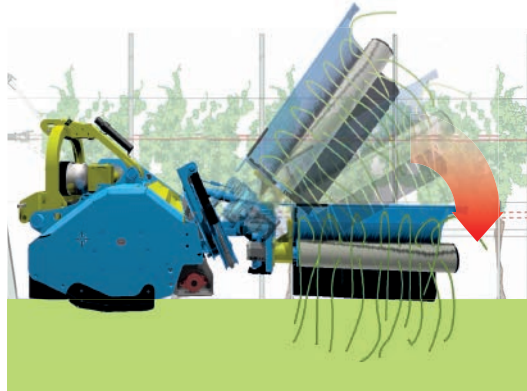

Apertura e chiusura braccio diserbatrice meccanica
 Arm opening and closing
 Antishock System: Anfahrtsicherung
 Apertura y cierre del brazo mecánico
 Ouverture et fermeture du bras

MOVIMENTO 2 / MOVEMENT 2

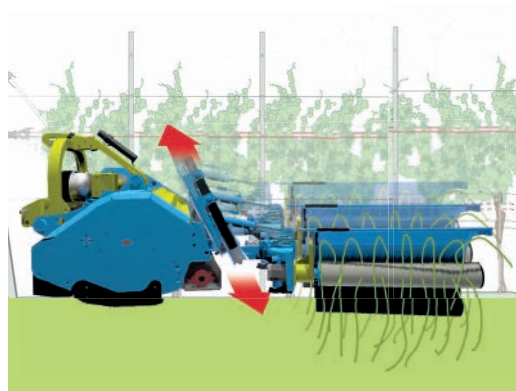

Regolazione altezza asse rullo
 Arm's height adjustment
 Einstellung Arbeitsposition
 Regulación de altura del rodillo
 Réglage hauteur axe du rouleau



Sistema antishock regolabile per l'attenuazione dell'urto
 Adjustable anti-shock system for shock absorption
 Einstellbares Anfahrtsicherung-System zur Stoßdämpfung
 Sistema anti impacto regulable para amortiguar golpe
 Système antichoc réglable pour atténuer l'impact



Rientro testata con sistema a molla
 Movement with spring system
 Schwenkung mit Federsystem
 Cierre y apertura del cabezal con sistema de muelle
 Retour de tête avec système de ressort



Regolazione giri rotore
 Rotor speed control
 Einstellung Rotorgeschwindigkeit
 Regulación vueltas rotor
 Réglage de la vitesse du rotor

